

ORIGINAL INSTRUCTION

PRODUCT SPECIFICATIONS

Motor.....	300W, 230-240V, 50 Hz, 1 Phase
Outer Filter	5 Microns
Inner Filter	1 Micron
Sound Rating	High Speed - 69 dB, Low Speed - 62 dB
Air Flow	High Speed 1675 CFM, Medium Speed 1035CFM, Low Speed - 945 CFM
Remote Control.....	Requires 2 "AAA" Batteries (not included)

GENERAL SAFETY RULES

WARNING!

READ AND UNDERSTAND ALL INSTRUCTIONS

Failure to follow all instructions listed below may result in electric shock, fire, and/or serious injury.

SAVE THESE INSTRUCTIONS

WORK AREA

1. Keep your work area clean and well lit. Cluttered benches and dark areas invite accidents.
2. Do not operate electric products in explosive atmospheres, such as in the presence of flammable liquids, gases, or dust.
3. Keep bystanders, children, and visitors away while mounting or maintaining the 3 speed air cleaner.

ELECTRICAL SAFETY

4. Grounded products must be plugged into an outlet properly installed and grounded in accordance with all codes and ordinances. Never remove the grounding prong or modify the plug in any way. Do not use any adapter plugs. Check with a qualified electrician if you are in doubt as to whether the outlet is properly grounded. If the product should electrically malfunction or break down, grounding provides a low resistance path to carry electricity away from the user.
5. Double insulated products are equipped with a polarized plug (one blade is wider than the other). This plug will fit in a polarized outlet only one way. If the plug does not fit fully in the outlet, reverse the plug. If it still does not fit, contact a qualified electrician to install a polarized outlet. Do not change the plug in any way. Double insulation eliminates the need for the three wire grounded power cord and grounded power supply system.
6. Avoid body contact with grounded surfaces such as pipes, radiators, ranges, and refrigerators. There is an increased risk of electric shock if your body is grounded.
7. Do not expose this product to rain or wet conditions. Water entering an electric product will increase the risk of electric shock.
8. Do not abuse the Power Cord. Never use the Power Cord to carry the product or pull the plug from an outlet. Keep the Power Cord away from heat, oil, sharp edges, or moving parts. Replace damaged Power Cords immediately. Damaged Power Cords increase the risk of electric shock.

PERSONAL SAFETY

9. Stay alert. Watch what you are doing, and use common sense when operating a power product. Do not use a power product while tired or under the influence of drugs, alcohol, or medication.
10. Dress properly. Do not wear loose clothing or jewelry. Contain long hair. Keep your hair, clothing, and gloves away from moving parts. Loose clothes, jewelry, or long hair can be caught in moving parts.
11. Avoid accidental starting. Be sure the Power Switch is off before plugging in.
12. Use safety equipment. Always wear eye protection. During installation use non-skid safety shoes and ANSI approved safety goggles.

TOOL USE AND CARE

13. Use the correct product for your application. The correct product will do the job better and safer at the rate for which it is designed.
14. Do not use the power product if the Power Switch does not turn it on or off. Any product that cannot be controlled with the Power Switch is dangerous and must be replaced.
15. Disconnect the Power Cord Plug from the power source before storing the tool.
16. Store idle products out of reach of children and other untrained persons. Products are dangerous in the hands of untrained users.
17. Maintain products with care. Keep products clean. Do not use a damaged product. Tag damaged products "Do not use" until repaired.
18. Check for misalignment or binding of moving parts, breakage of parts, and any other condition that may affect the product's operation. If damaged, have the product serviced before using. Many accidents are caused by poorly maintained products.

SERVICE

20. **Product service must be performed only by qualified repair personnel.** Service or maintenance performed by unqualified personnel could result in a risk of injury.

SPECIFIC SAFETY RULES

1. **Maintain labels and nameplates on the Air Filtration System.** These carry important information. If unreadable or missing, contact the seller for a replacement.
2. **Always wear safety impact eye goggles when mounting or performing maintenance on the Air Filtration System.** Using personal safety devices reduce the risk for injury.
3. **Maintain a safe working environment.** Keep the work area well lit. Make sure there is adequate surrounding workspace. Always keep the work area free of obstructions, grease, oil, trash, and other debris. Do not use a power product in areas near flammable chemicals, dusts, and vapors. Do not use this product in a damp or wet location.
4. **If placing this 3 SPEED AIR CLEANER on a table or shelf, make sure that the machine is placed securely on a flat, level surface, capable of supporting the weight of the machine.**

5. If attaching the Air Filtration System to a ceiling, make sure the machine is attached securely to joists capable of supporting the weight of the machine.
6. Make sure the Switch is in the “Off” position before plugging in the power cord.
7. Keep the Filter Net (1) and the Filter Bag (2) clean, in place, and in good working order.
8. Always unplug the 3 SPEED AIR CLEANER from its electrical outlet before performing any inspection, maintenance, or cleaning procedures.
9. **WARNING!** People with pacemakers should consult their physician(s) before using this product. Operation of electrical equipment in close proximity to a heart pacemaker could cause interference or failure of the pacemaker.

GROUNDING

WARNING!

Improperly connecting the grounding wire can result in the risk of electric shock. Check with a qualified electrician if you are in doubt as to whether the outlet is properly grounded. Do not modify the power cord plug provided with the product. Never remove the grounding prong from the plug. Do not use the product if the power cord or plug is damaged. If damaged, have it repaired by a service facility before use. If the plug will not fit the outlet, have a proper outlet installed by a qualified electrician.

GROUNDED PRODUCT: PRODUCTS WITH THREE PRONG PLUGS

1. Products marked with “Grounding Required” have a three wire cord and three prong grounding plug. The plug must be connected to a properly grounded outlet. If the product should electrically malfunction or break down, grounding provides a low resistance path to carry electricity away from the user, reducing the risk of electric shock. **(See Figure A.)**
2. The grounding prong in the plug is connected through the green wire inside the cord to the grounding system in the tool. The green wire in the cord must be the only wire connected to the products grounding system and must never be attached to an electrically “live” terminal. **(See Figure A.)**
3. Your product must be plugged into an appropriate outlet, properly installed and grounded in accordance with all codes and ordinances. The plug and outlet should look like those in the following illustration. **(See Figure A.)**

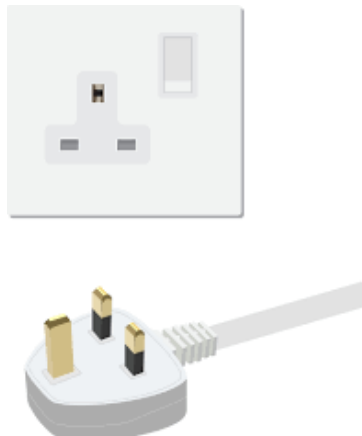

EXTENSION CORDS

1. **Grounded** tools require a three wire extension cord. **Double Insulated** tools can use either a two or three wire extension cord.
2. As the distance from the supply outlet increases, you must use a heavier gauge extension cord. Using extension cords with inadequately sized wire causes a serious drop in voltage, resulting in loss of power and possible product damage. **(See Figure C.)**
3. The smaller the gauge number of the wire, the greater the capacity of the cord. For example, a 14 gauge cord can carry a higher current than a 16 gauge cord. **(See Figure C.)**
4. When using more than one extension cord to make up the total length, make sure each cord contains at least the minimum wire size required. **(See Figure C.)**
5. If you are using one extension cord for more than one product, add the name plate amperes and use the sum to determine the required minimum cord size. **(See Figure C.)**
6. If you are using an extension cord outdoors, make sure it is marked with words to indicate it is acceptable for outdoor use.
7. Make sure your extension cord is properly wired and in good electrical condition. Always replace a damaged extension cord or have it repaired by a qualified electrician before using it.
8. Protect your extension cords from sharp objects, excessive heat, and damp or wet areas.

UNPACKING

When unpacking. Check to make sure all the parts shown on the **Parts List** are included.

ASSEMBLY AND OPERATING INSTRUCTIONS

CAUTION: Always make sure the Power Cord of the 3 SPEED AIR CLEANER is unplugged from its electrical outlet prior to making any adjustments to the product.

1. Locate the desired ceiling location and ceiling joists, upon which to attach the **3 SPEED AIR CLEANER**.
2. With assistance or lifting equipment (not included), raise the unit to the desired location.
Caution: Make sure other people or pets are well clear of the area during this procedure.
3. Align the four Eye Bolt (10) with the ceiling joists and measure for eyelet bolt location. Insert four eyelet bolts (not included) through the ceiling into the underside of the ceiling joists.

Note: The eyelet bolts must be capable of supporting the weight of the Air Filtration System, and be of compatible size with the Eye Bolt (10). When hanging the unit, make sure each Eye Bolt (10) fits completely inside the loop of each eyelet bolt to ensure a safe mounting of the 3 SPEED AIR CLEANER from its electrical outlet prior to making any adjustments to the product.

Manual Control Operation

Note: The fuse is housed on the Switch Plate (22). If the unit suffers a fuse failure, unscrew the fuse cover, remove and replace the fuse, and screw the cover back in place.

1. Plug the Power Cord (19) into an outlet.
2. Press the "On/Speed" button once for high power, twice for medium, and three times for low power. The corresponding LED will light to show the unit's speed.
3. When you are finished using the unit, press the off button. (See **FIGURE 1.**)

FIGURE 1



FIGURE 2



Remote Control (28) Usage

1. Press the "On/Speed" button once for high power, twice for medium, and three times for low power.
2. Press the Time button once for 1 hr. automatic shut off, twice for 2 hour automatic shut off, or three times for 4 hour automatic shut off.
3. To turn off the unit manually, press the Off button. (See **FIGURE 2.**)

Note: To change batteries in the Remote Control (28); remove the back panel, replace the two "AAA" batteries, and then replace the back panel.

INSPECTION, MAINTENANCE, AND CLEANING

1. **WARNING!** Make sure the Switch Plate (22) of the 3 SPEED AIR CLEANER is in its “OFF” position and that the product is unplugged from its electrical outlet before performing any inspection, maintenance, or cleaning procedures.

2. **BEFORE EACH USE**, inspect the general condition of the 3 SPEED AIR CLEANER. Check for loose screws, misalignment or binding of moving parts, cracked or broken parts, damaged electrical wiring, and any other condition that may affect its safe operation. If abnormal noise or vibration occurs, have the problem corrected before further use. Do not use damaged equipment.

Note: During this procedure, wear ANSI approved safety goggles and dust protection.

3. Periodically, inspect the Filter Net (1) for dirt and debris, and if necessary, remove and change the Filter Net (1). On the rear of the unit, unlatch the two metal clasps to release the Filter Net (1) Remove the Filter Net (1) and inspect it to see whether it needs a simple cleaning, or it needs replacement. Reinsert a Filter Net (1) (old or new) and lock it in place with the two clasps.(See FIGURE D).

4. Periodically, inspect the Inner Filter (2) for dirt and debris, and if necessary, remove and change the Inner Filter (2). On the rear of the unit, unlatch the two metal clasps to release the Filter Net (1). Remove the Filter Net (1). Then, remove the Inner Filter (2) and inspect it. If necessary, use compressed air to blow dirt and debris from the Inner Filter (2) Replace the Inner Filter (2) and the Filter Net (1) in the rear of the unit and lock them in place with the two clasps. (See FIGURE E).

- When the filter becomes blocked an alarm will sound (e.g beeping noise) and the top row of lights on the control panel will start flashing (See FIGURE F).

- Once the filters are cleaned or replaced you will need to reset the system by holding in the ‘On Speed Button’ for around 10 seconds, then release.

Filter Net (1)

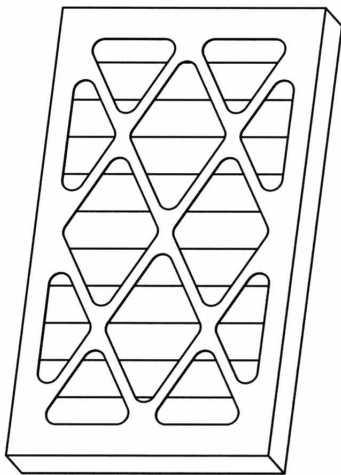

Figure D

Inner Filter (2)

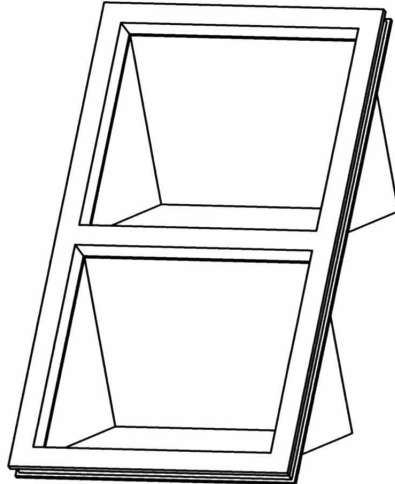

Figure E

Lights will start flashing

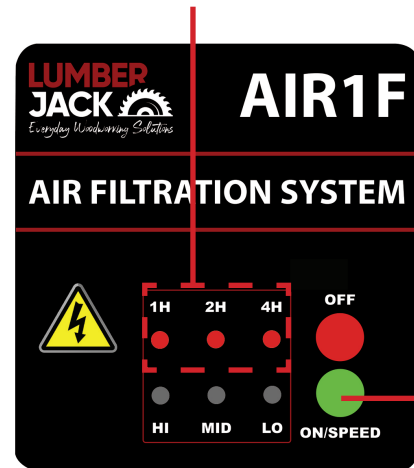

Figure F

On Speed Button

TROUBLESHOOTING

Note: Any repairs suggested below should be completed by an authorised service technician.

Trouble	Probable Cause	Correction
Motor does not run when power switch is pressed on.	<ol style="list-style-type: none"> 1 Blown fuse. 2. Switch is burned out. 3. Connection wire is loose or damaged. 	<ol style="list-style-type: none"> 1 Replace fuse. 2. Replace the Switch. 3. Tighten or replace the wire.
Motor does not run at full speed.	<ol style="list-style-type: none"> 1. Power voltage is too low. 2. Motor is damaged. 	<ol style="list-style-type: none"> 1. Test voltage. 2. Check and repair motor.
Motor will not reach full power	<ol style="list-style-type: none"> 1 Incorrect power wiring. 2. Overload. 	<ol style="list-style-type: none"> 1 Replace incorrect power wiring. 2. Reduce load by cleaning filters as necessary.
Motor overheats.	<ol style="list-style-type: none"> 1. Using wrong voltage. 2. Motor is damaged. 	<ol style="list-style-type: none"> 1. Check voltage and voltage label. 2. Check and repair the Motor.
Insufficient suction power.	<ol style="list-style-type: none"> 1. Inlet port blocked. 2. Filter Bag is full. 3. Outlet port blocked. 	<ol style="list-style-type: none"> 1. Clean inlet port. 2. Empty Filter Bag. 3. Clean the outlet port or adjust the direction of the outlet.
Unit is shaking.	<ol style="list-style-type: none"> 1. The unit isn't properly anchored. 2. The unit isn't level. 3. Worn or damaged power cord. 	<ol style="list-style-type: none"> 1. Mount the unit firmly. 2. Level the unit. 3. Repair or replace power cord.

PARTS BREAKDOWN & PARTS LIST

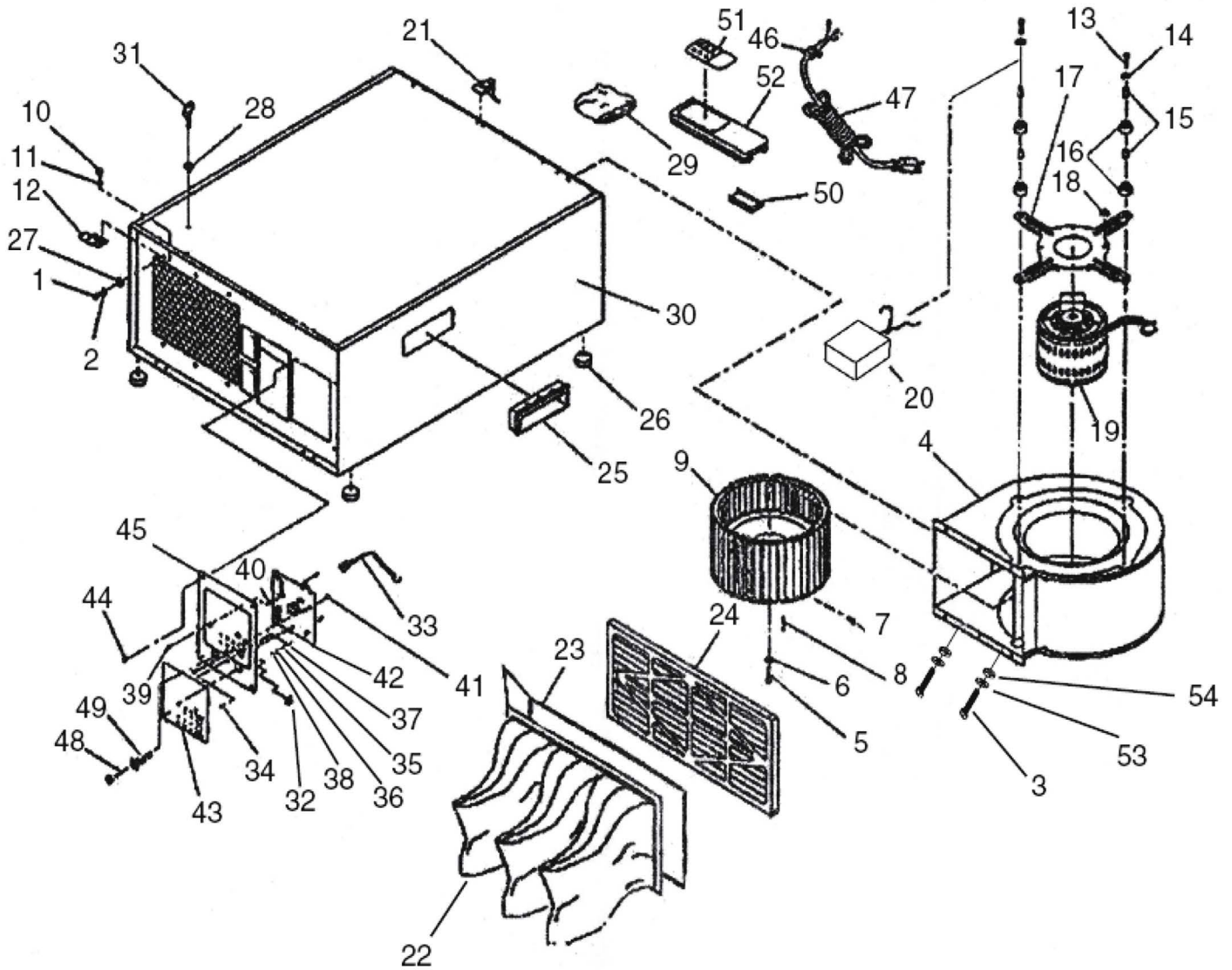

REF	DESCRIPTION
1	PHLP HO SCA M6-1 X 16
2	LOCK WASHER 6MM
3	PHLP HO SCA M4 .7 X 8
4	FAN HOUSING
5	CAP SCREW M6-1 X 20 (LH)
6	FLANGE DISK 6.5 X 44MM
7	HEX BOLT MB-1.25 X 12
8	KEY 4 X 4 X 20MM
9	FAN
10	HEX BOLT M6-1 X 10
11	FLAT WASHER 6MM
12	FLANGE BRACKET
13	HEX BOLT M6-1 X 30
14	FLAT WASHER 6MM
15	SLEEVE
16	SPACER
17	FLANGE
18	LOCK NUT MS-.8
19	MOTOR

20	CAPACITOR 6 MFD 450 VAC
21	FILTER RETAINING LATCH
22	SECOND FILTER 1-MICRON
23	FOAM SEAL V4" X 1" X 70"
24	PRIMARY FILTER 5-MICRON
25	HANDLE
26	RUBBER FOOT
27	FLAT WASHER 6 MM
28	RIVET NUT M6 X 8
29	MOUNT AND BOLT BAG
30	HOUSING
31	EYE BOLT M6-1 X 20
32	BOLT (SPECIAL) M3-.5 X 6
33	PC WIRING HARNESS
34	PHLP HO SCA M4-.7 X 6
35	LOCK WASHER 4MM
36	FLAT WASHER 4MM
37	HEX NUT M4-.7
38	EXT TOOTH WASHER 4MM
39	PHLP HD SCA (SPECIAL)

40	SPACER (SPECIAL)
41	PHLP HO SCA M3-.5 X 6
42	PC BOARD
43	LABEL (CONTROLS)
44	PHLP HD SCA M4-.7 X 10
45	CONTROL PANEL
46	STRAIN RELIEF
47	POWER CORD 3-WIRE 18-GA
48	1-t-8" FUSE 5-AMP (250VAC)
49	FUSE HOLDER
50	REMOTE CONTROL COVER
51	LABEL (REMOTE)
52	REMOTE CONTROL
53	FLAT WASHER 4MM
54	LOCK WASHER 4MM

WIRING DIAGRAM

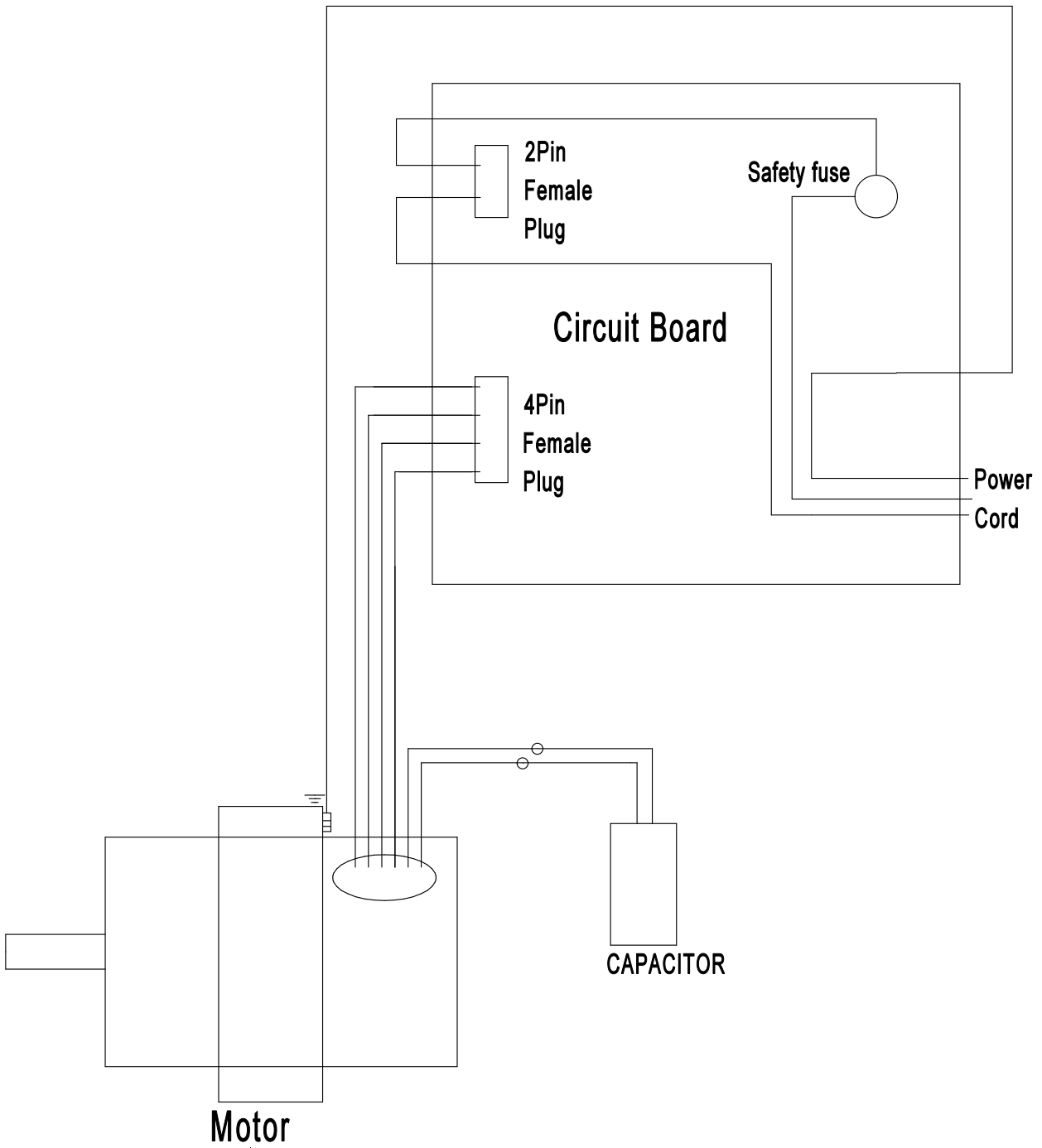

DECLARATION OF CONFORMITY

The Importer:
TOOLSAVE LTD

Unit C, Manders Ind. Est.,
Old Heath Road, Wolverhampton,
WV1 2RP.

Declare that the product:

Designation: Air Filtration System
Model: AIR1F

Standards & technical specifications referred to:

EC Council Directive 2006/42/EC Machinery

Certificate No.	50326043 001
Report No.	EN 55014-1:2017
	EN 55014-2:2015

Authorised Technical File Holder: Bill Evans

01/01/2025

The Director

